

D ❄️

RAFFINATO 90 & 180 mm

DESCRIPTION: Wall TEXTURE: Polished (on a single-side only)

Pallet Overview - 90 mm

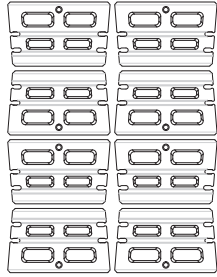

Pallet Overview - 180 mm

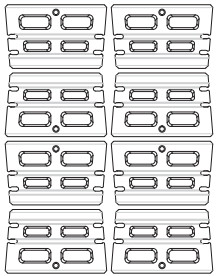

Polished
Beige Cream

Polished
Greyed Nickel

Polished
Onyx Black

90 mm

Specifications per pallet

	Imperial	Metric
Dimension Front (L x D x H)	15 5/8 x 9 5/8 x 3 9/16	397 x 245 x 90
Dimension Back (L x D x H)	14 1/4 x 9 5/8 x 3 9/16	362 x 245 x 90
Cubing	23.08 ft ²	2.14 m ²
60 units / pallet	78.15 lin ft	23.82 lin m
Approx. Weight	1 948 lbs	884 kg
Minimum radius	8.5 ft	2.6 m
Number of rows	3	
Coverage per row	7.69 ft ²	0.71 m ²
Linear coverage per row	26.05 lin ft	7.94 lin m



60 units / pallet

180 mm

Specifications per pallet

	Imperial	Metric
Dimension Front (L x D x H)	15 5/8 x 9 5/8 x 7 1/16	397 x 245 x 180
Dimension Back (L x D x H)	14 1/4 x 9 5/8 x 7 1/16	362 x 245 x 180
Cubing	23.08 ft ²	2.14 m ²
30 units / pallet	39.07 lin ft	11.91 lin m
Approx. Weight	1 936 lbs	878 kg
Minimum radius	8.5 ft	2.6 m
Number of rows	3	
Coverage per row	7.69 ft ²	0.71 m ²
Linear coverage per row	13.02 lin ft	3.97 lin m



30 units / pallet

NOTES

See page 6 for icons description.

COMPATIBLE CAPS

See page 145 for product compatibility.

Polished only on one side, Smooth on the other side.

See page 146 to 161 for more technical information.

Polished is made-to-order, minimum order of 500 sq. ft. Deposit required.



RAFFINATO 90 & 180 mm

DESCRIPTION: Wall double-sided TEXTURE: Smooth

90 mm

Specifications per pallet



64 units / pallet

	Imperial	Metric
Dimension Front (L × D × H)	15 5/8 × 9 13/16 × 3 9/16	397 × 249 × 90
Dimension Back (L × D × H)	14 1/4 × 9 13/16 × 3 9/16	362 × 249 × 90
Cubing	24.61 ft ²	2.29 m ²
Approx. Weight	2 060 lbs	934 kg
Minimum radius	8.5 ft	2.6 m
Number of rows	8	
Coverage per row	3.08 ft ²	0.29 m ²
Linear coverage per row	10.42 lin. ft	3.18 lin. m

180 mm

Specifications per pallet



32 units / pallet

	Imperial	Metric
Dimension Front (L × D × H)	15 5/8 × 9 13/16 × 7 1/16	397 × 249 × 180
Dimension Back (L × D × H)	14 1/4 × 9 13/16 × 7 1/16	362 × 249 × 180
Cubing	24.61 ft ²	2.29 m ²
Approx. Weight	2 071 lbs	939 kg
Minimum radius	8.5 ft	2.6 m
Number of rows	4	
Coverage per row	6.15 ft ²	0.57 m ²
Linear coverage per row	10.42 lin. ft	3.18 lin. m

Pallet Overview - 90 mm & 180 mm

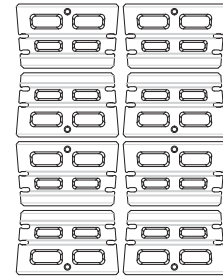

Caffè Crema

Smooth



Beige Cream

Smooth

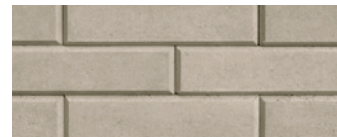

Greyed Nickel

Smooth

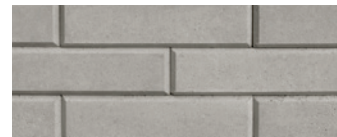

Shale Grey

Smooth



Onyx Black

Smooth

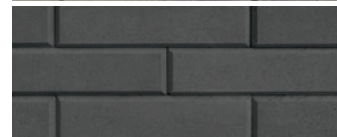

NOTES

See page 6 for icons description.

COMPATIBLE CAPS

See page 145 for product compatibility.

When building a double-sided wall one pallet will cover an average of 23.53 ft².

See page 146 to 161 for more technical information.

D ❄️

RAFFINATO 90 & 180 mm

DESCRIPTION: Pillars, corners and edges **TEXTURE:** Polished (on a single-side only)

Pallet Overview - 90 mm

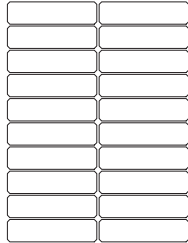

Pallet Overview - 180 mm

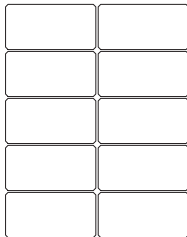

90 mm

Specifications per pallet

	Imperial	Metric
 Product dimension (L x D x H)	14 1/16 x 9 5/8 x 3 7/16	357 x 245 x 90
Cubing	40 units	40 units
Approx. Weight	1 559 lbs	707 kg
40 units / pallet	Number of rows	2
Pillar height	35 7/16 in	900 mm

180 mm

Specifications per pallet

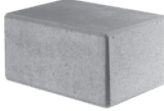
	Imperial	Metric
 Product dimension (L x D x H)	14 1/16 x 9 5/8 x 7 1/16	357 x 245 x 180
Cubing	20 units	20 units
Approx. Weight	1 557 lbs	706 kg
20 units / pallet	Number of rows	2
Pillar height	35 7/16 in	900 mm



Polished
Beige Cream

Polished
Greyed Nickel

Polished
Onyx Black

NOTES

See page 6 for icons description.

COMPATIBLE CAPS

See page 145 for product compatibility.

Polished only on one side, Smooth on the other side.

See page 146 to 161 for more technical information.

Polished is made-to-order, minimum order of 500 sq. ft. Deposit required.



RAFFINATO 90 & 180 mm

DESCRIPTION: Pillars, corners and edges TEXTURE: Smooth

90 mm

Specifications per pallet	Imperial	Metric
 Product dimension (L x D x H)	14 1/8 x 9 13/16 x 3 9/16	359 x 249 x 90
Cubing	48 units	48 units
Approx. Weight	1 548 lbs	702 kg
48 units / pallet	Number of rows	2
Pillar height	42 1/2 in	1 080 mm

180 mm

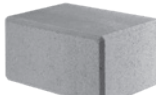
Specifications per pallet	Imperial	Metric
 Product dimension (L x D x H)	14 1/8 x 9 13/16 x 7 1/16	359 x 249 x 180
Cubing	24 units	24 units
Approx. Weight	1 529 lbs	694 kg
24 units / pallet	Number of rows	2
Pillar height	42 1/2 in	1 080 mm

Pallet Overview - 90 mm

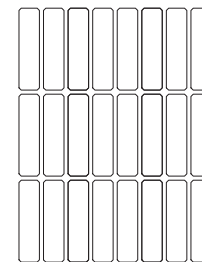

Pallet Overview - 180 mm

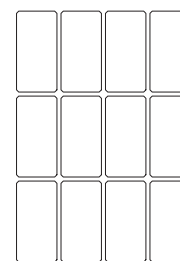

NOTES

See page 6 for icons description.

COMPATIBLE CAPS

See page 145 for product compatibility.

See page 146 to 161 for more technical information.

Caffé Crema

Smooth



Beige Cream

Smooth



Greyed Nickel

Smooth



Shale Grey

Smooth



Onyx Black

Smooth



TECHO—BLOC

DESIGN CHART RAFFINATO 180 mm

(EQUIVALENT TO TWICE THE RAFFINATO 90 mm)
SETBACK POSITION

CLEAN SAND/GRAVEL/ SAND AND GRAVEL MIXES ($\phi=34^\circ$, $\gamma = 120$ pcf)
GEOGRID: MIRAGRID 3XT BY TENCATE (RFd=1.10, RFcr=1.45, RFid=1.25, Cds=0.9, Ci=0.9)

CASE N° 1 :
No Surcharge
No Backslope
No Toe Slope

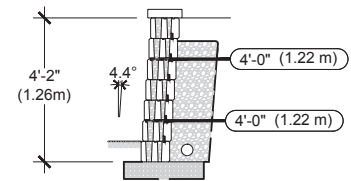
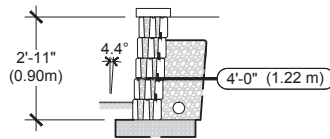
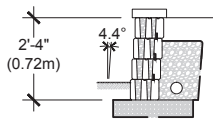

VISIT WWW.TECHO-BLOC.COM FOR COMPLETE DESIGN CHART DOCUMENT
(USA AND CANADA VERSIONS)

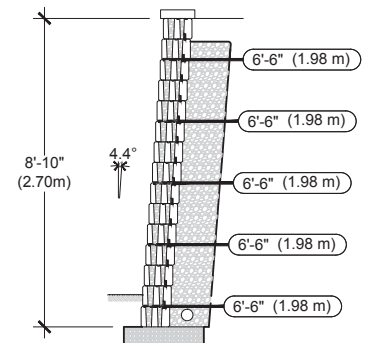
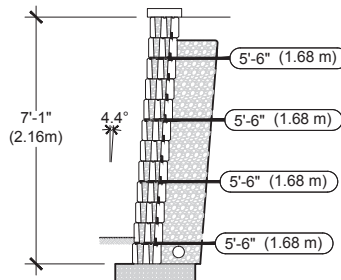
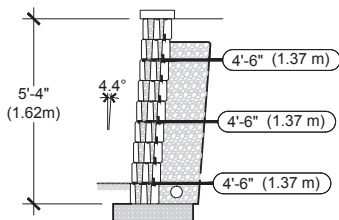

1. The information contained in the design charts is supplied for information purposes only and as such should only be used for preliminary designs.
2. The height (H) of the wall is the total height from the leveling pad to the top of the wall not including the thickness of the cap.
3. Soil parameters: reinforced soil ($\phi = 34^\circ$, $\gamma = 120$ pcf); retained soil ($\phi = 34^\circ$, $\gamma = 120$ pcf); foundation soil ($\phi = 34^\circ$, $\gamma = 120$ pcf)
4. A qualified engineer should be consulted for the final design to be used for construction.
5. The foundation soil must be able to support the wall system. The bearing capacity of the foundation soil, settlement, and global stability must be verified and validated by a qualified geotechnical engineer.
6. The seismic analysis is not included.
7. The design charts do not apply to tiered walls.
8. The charts assume that the walls are constructed in accordance with Tehco-Bloc specifications, good construction practice and an adequate drainage system.
9. The geogrid layout has been optimized to satisfy the design requirements of the NCMA's Design Manual for Segmental Retaining Walls, 3rd Edition.
10. The minimum burial depth must be 6 in (150 mm) or 10% of the exposed height, whichever is greater.
11. Engineering judgement should be used when interpolating between heights.
12. Tehco-Bloc and its predecessors, successors, beneficiaries, employees, associates, administrators and insurers accepts no liability for the incorrect use of information contained in the design charts.
13. For further information, please contact our technical service department.

INSTALLATION GUIDE

RETAINING WALLS - RAFFINATO 90 mm & 180 mm

The different modules of the Raffinato retaining wall allow the installation of different block combinations.

Two combinations are shown as an example. Combinations are 15 5/8" (398 mm) long and 10 5/8" (270 mm) high.

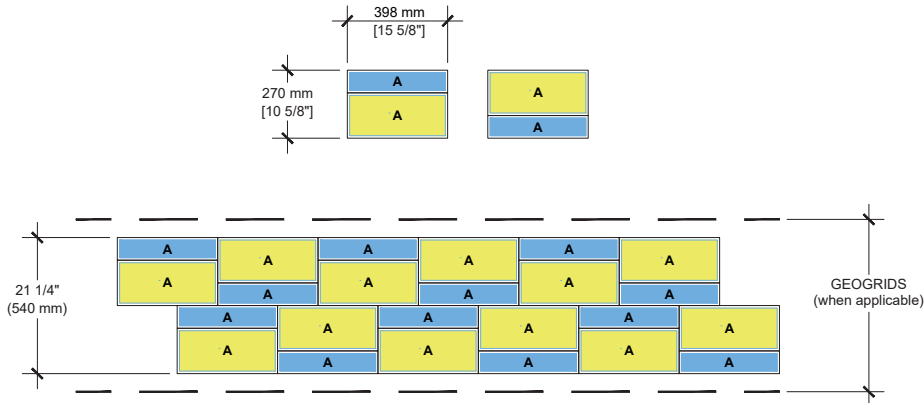

NUMBER OF BLOCKS REQUIRED	MODULE
RAFFINATO	A
67 % of the surface - Raffinato 90 mm	2
33 % of the surface - Raffinato 180 mm	2

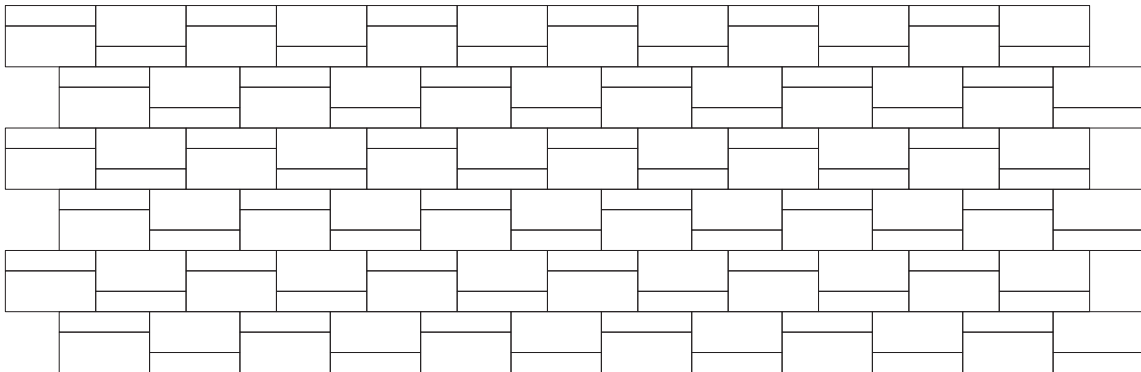

INSTALLATION GUIDE

FREESTANDING WALLS - RAFFINATO 90 MM & 180 MM

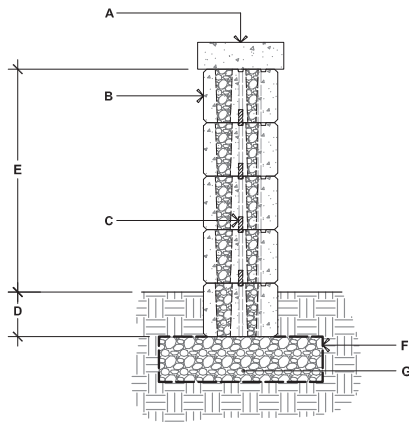

RAFFINATO 90 mm & 180 mm

- A.** TECO-BLOC CAP UNIT SECURED TO UNIT BELOW WITH CONCRETE ADHESIVE
- B.** RAFFINATO 90 mm AND 180 mm DOUBLE-SIDED WALL UNITS SECURE EACH ROW WITH CONCRETE ADHESIVE
- C.** CONNECTOR
- D.** EMBEDMENT DEPTH, 6" (150 mm) MIN.
- E.** 29 7/16" (750 mm) MAX.
- F.** GEOTEXTILE
- G.** COMPACTED GRANULAR LEVELING PAD, 6" (150 mm) THICK MIN. THICKNESS ACCORDING TO PROJECT SPECIFIC CONDITIONS

90° CORNER OF A DOUBLE-SIDED WALL

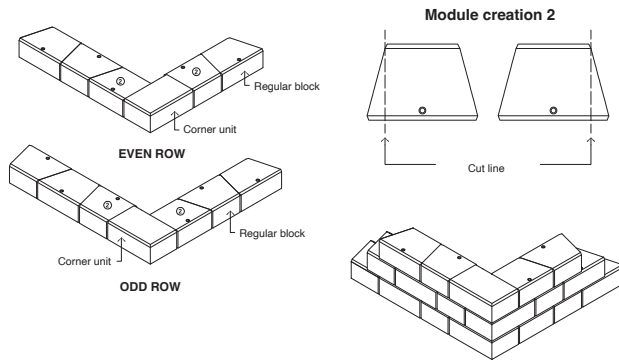

DOUBLE-SIDED WALL RADIUS

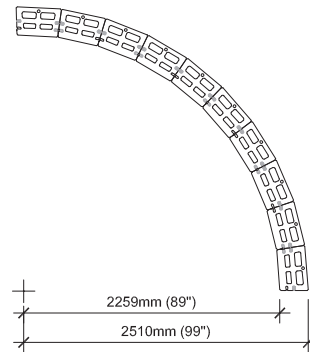

It is the user's responsibility to verify for the quantity of materials required.

DOUBLE SIDED WALL - END OF A STRAIGHT WALL

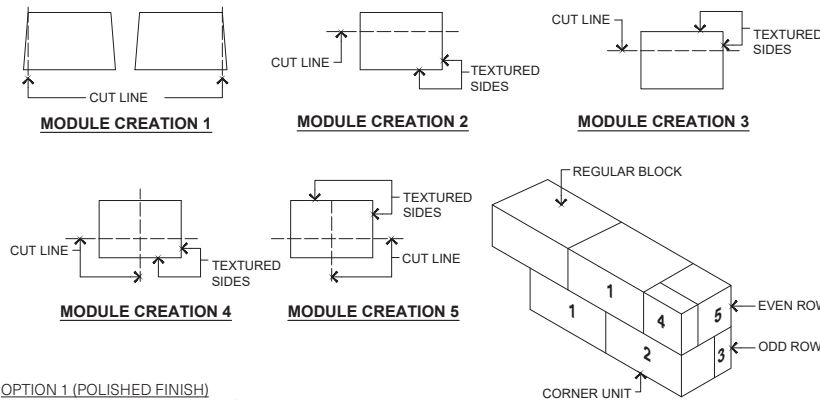

GENERAL NOTES

- 1.** Alternate odd and even rows.
- 2.** Stagger joints from one row to the next.
- 3.** Glue all modules at each row with concrete adhesive.
- 4.** Cavities, grooves and connectors are not illustrated to avoid overloading the image.

OPTION 1 (POLISHED FINISH)

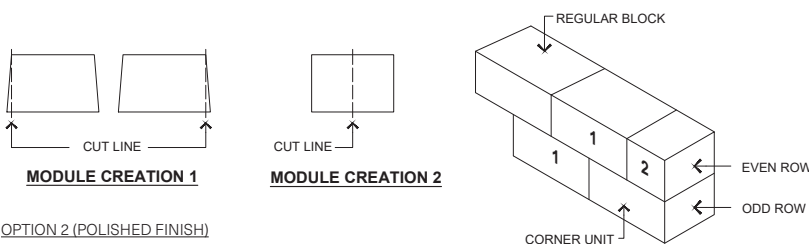

OPTION 2 (POLISHED FINISH)

PLEASE REFER TO P.4 FOR THE CORRECT USE AND LIMITATIONS OF PROVIDED TECHNICAL INFORMATION.

INSTALLATION GUIDE

PILLARS - RAFFINATO 90 mm & 180 mm

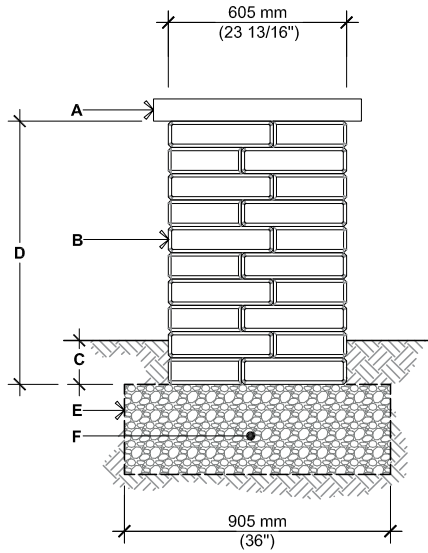

RAFFINATO 90 mm

- A.** STONEDGE COLLECTION PILLAR CAP UNIT, SECURE TO UNITS BELOW WITH CONCRETE ADHESIVE
- B.** RAFFINATO 90 mm PILLAR UNIT SECURE EACH ROW WITH CONCRETE ADHESIVE
- C.** EMBEDMENT DEPTH: 150 mm (6") MIN.
- D.** 1 080 mm (42 ½"), MAXIMUM HEIGHT
- E.** GEOTEXTILE
- F.** COMPACTED GRANULAR BASE 150 mm (6") THICK MIN. THICKNESS ACCORDING TO PROJECT SPECIFIC CONDITIONS

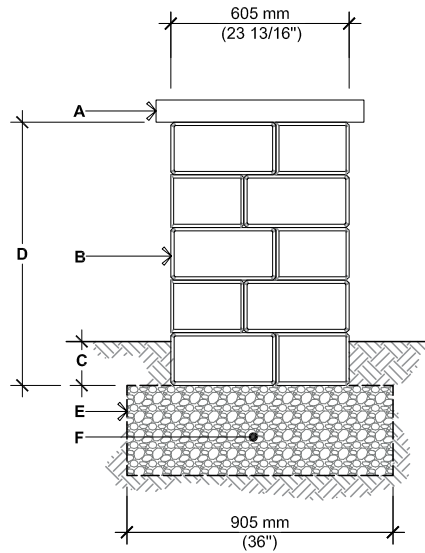

RAFFINATO 180 mm

- A.** STONEDGE COLLECTION PILLAR CAP UNIT, SECURE TO UNITS BELOW WITH CONCRETE ADHESIVE
- B.** RAFFINATO 180 mm PILLAR UNIT SECURE EACH ROW WITH CONCRETE ADHESIVE
- C.** EMBEDMENT DEPTH: 150 mm (6") MIN.
- D.** 1080 mm (42 ½"), MAXIMUM HEIGHT
- E.** GEOTEXTILE
- F.** COMPACTED GRANULAR BASE 150 mm (6") THICK MIN. THICKNESS ACCORDING TO PROJECT SPECIFIC CONDITIONS

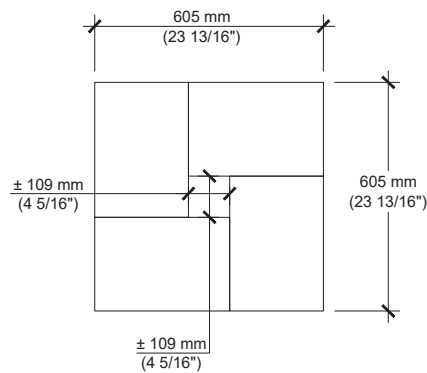

For all possible combinations of pillars and caps, please refer to the correspondence table on page 145

INSTALLATION GUIDE

PILLARS - RAFFINATO 90 mm & 180 mm

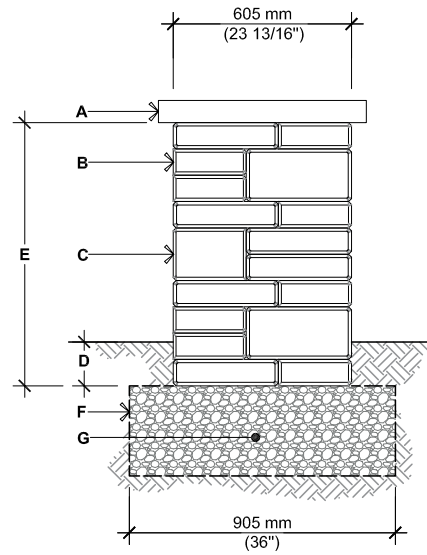
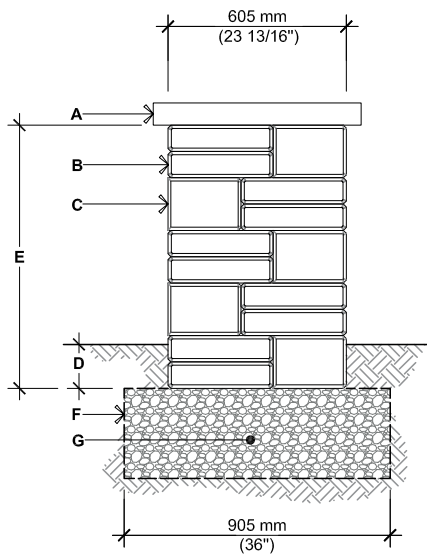

○ RAFFINATO 90 mm & 180 mm
OPTION A

- A. STONEDGE COLLECTION PILLAR CAP UNIT, SECURE TO UNITS BELOW WITH CONCRETE ADHESIVE
- B. RAFFINATO 90 mm PILLAR UNIT SECURE EACH ROW WITH CONCRETE ADHESIVE
- C. RAFFINATO 180 mm PILLAR UNIT SECURE EACH ROW WITH CONCRETE ADHESIVE
- D. EMBEDMENT DEPTH: 150 mm (6") MIN.
- E. 1 080 mm (42 ½"), MAXIMUM HEIGHT
- F. GEOTEXTILE
- G. COMPACTED GRANULAR BASE 150 mm (6") THICK MIN. THICKNESS ACCORDING TO PROJECT SPECIFIC CONDITIONS

○ RAFFINATO 90 mm & 180 mm
OPTION B

- A. STONEDGE COLLECTION PILLAR CAP UNIT, SECURE TO UNITS BELOW WITH CONCRETE ADHESIVE
- B. RAFFINATO 90 mm PILLAR UNIT SECURE EACH ROW WITH CONCRETE ADHESIVE
- C. RAFFINATO 180 mm PILLAR UNIT SECURE EACH ROW WITH CONCRETE ADHESIVE
- D. EMBEDMENT DEPTH: 150 mm (6") MIN.
- E. 1 080 mm (42 ½"), MAXIMUM HEIGHT
- F. GEOTEXTILE
- G. COMPACTED GRANULAR BASE 150 mm (6") THICK MIN. THICKNESS ACCORDING TO PROJECT SPECIFIC CONDITIONS

STEPS

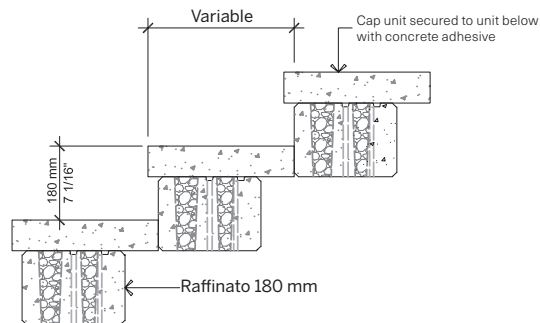
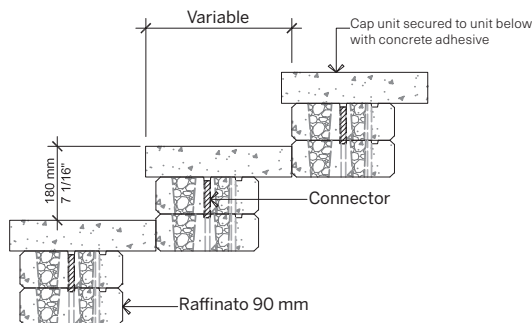

For all possible combinations of pillars and caps, please refer to the correspondence table on page 145

Check with your local Building Codes to determine any restrictions or guidelines regarding the dimensions of steps (including riser height and step tread) as well as handrail specifications.

PLEASE REFER TO P.4 FOR THE CORRECT USE AND LIMITATIONS OF PROVIDED TECHNICAL INFORMATION.

INSTALLATION GUIDE

GRILL ISLAND - RAFFINATO SMOOTH 90 mm & 180 mm

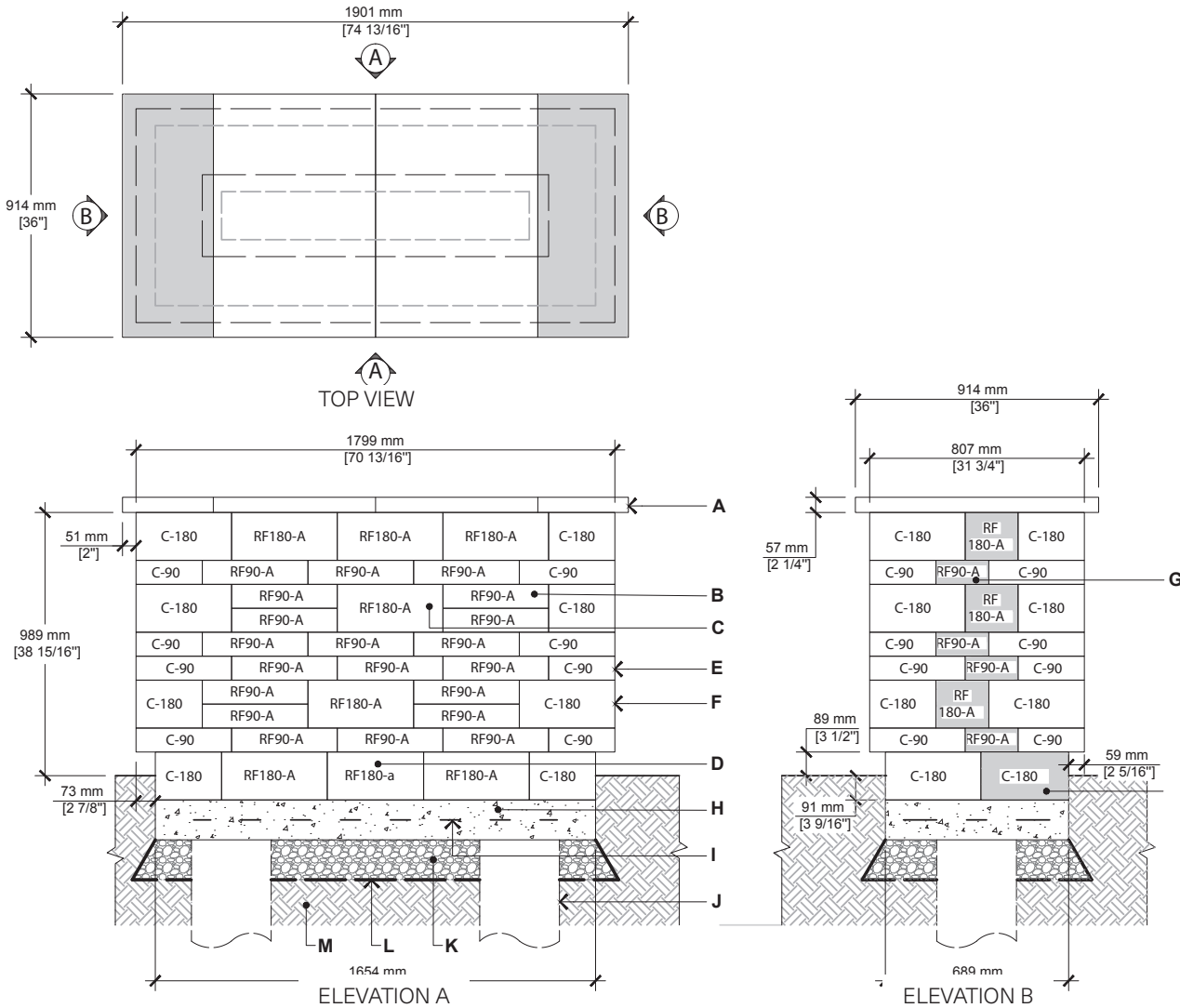

- A.** YORK COUNTER TOP 24" x 36" x 2 1/4" (CUT ON FIELD AS REQUIRED)
- B.** RAFFINATO 90 mm UNIT (A) – LONG FACE EXPOSED (SHOWN WITH UPPERCASE LETTER)
- C.** RAFFINATO 180 mm UNIT (A) – LONG FACE EXPOSED (SHOWN WITH UPPERCASE LETTER)
- D.** RAFFINATO 180 mm UNIT (A) – SHORT FACE EXPOSED (SHOWN WITH LOWERCASE LETTER)
- E.** RAFFINATO 90 mm PILLAR UNIT
- F.** RAFFINATO 180 mm PILLAR UNIT
- G.** RAFFINATO UNIT CUT ON FIELD AS REQUIRED
- H.** CAST IN PLACE CONCRETE SLAB 4350 psi (30 MPa), 5" (125 mm) THICK
- I.** 4X4-4/4 (102X102-MW25.8XMW25.8) WELDED WIRE MESH AND/OR REBAR AS PER SITE CONDITIONS
- J.** 12" (300 mm) DIA. CONCRETE PILLAR, AS PER LOCAL CODE
- K.** 3/4" (20 mm) CLEAN STONE
6" (150 mm) THICK MIN. AS PER SITE CONDITIONS
- L.** GEOTEXTILE
- M.** NATURAL SOIL OR COMPACTED BACKFILL

QUANTITY OF MATERIALS REQUIRED

- York Counter top 24" x 36" x 2 1/4": **4**
- Raffinato 90 mm wall unit: **48 A**
- Raffinato 180 mm wall unit: **22 A**
- Raffinato 90 mm pillar unit: **16**
- Raffinato 180 mm pillar unit: **16**

NOTE: Appliances and utilities may vary for each project and are not shown on this drawing. This drawing is shown for inspiration only and surplus or shortage of materials may result. It is the user's responsibility to verify for the quantity of materials required. Secure the blocks using a heat resistant concrete adhesive. The installer must ensure that the installation and use of the grill island comply with local regulations and code requirements. Concrete pillars extending to frost line may be required as per local code. Check your local building code before installing.

INSTALLATION GUIDE

GRILL ISLAND - RAFFINATO POLISHED 90 mm & 180 mm

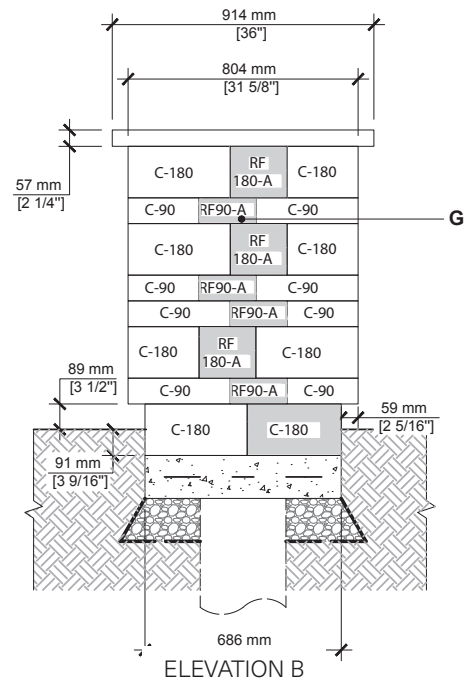
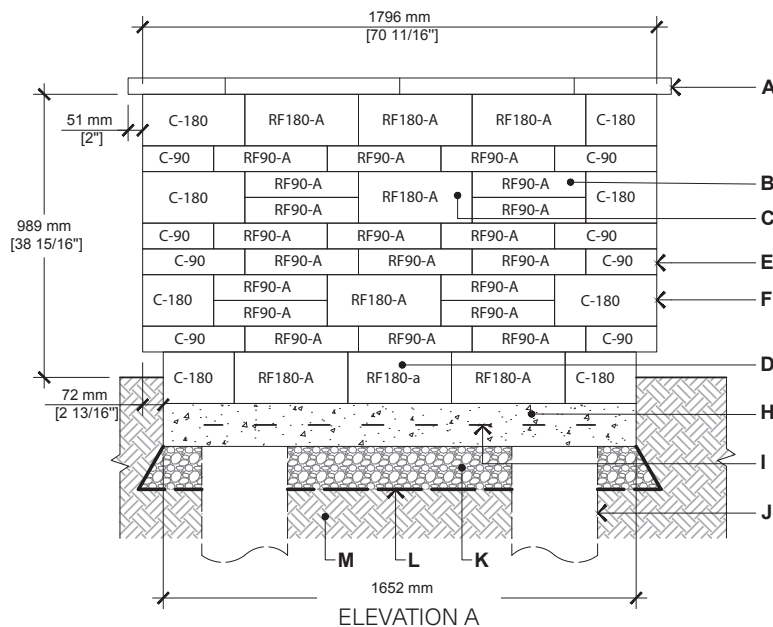
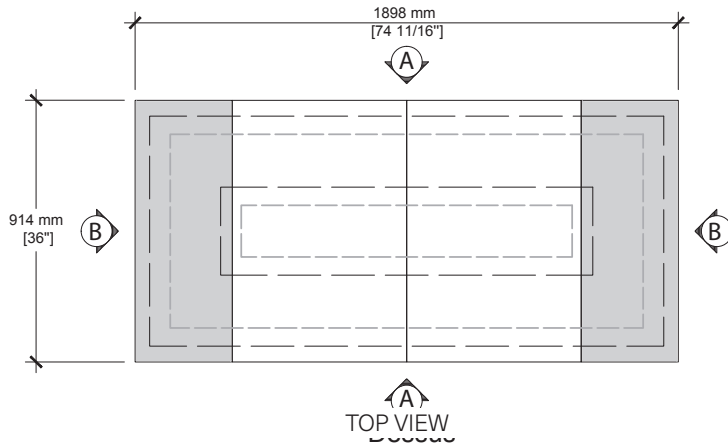

- A.** YORK COUNTER TOP 24" x 36" x 2 1/4" (CUT ON FIELD AS REQUIRED)
- B.** RAFFINATO 90 mm UNIT (A) – LONG FACE EXPOSED (SHOWN WITH UPPERCASE LETTER)
- C.** RAFFINATO 180 mm UNIT (A) – LONG FACE EXPOSED (SHOWN WITH UPPERCASE LETTER)
- D.** RAFFINATO 180 mm UNIT (A) – SHORT FACE EXPOSED (SHOWN WITH LOWERCASE LETTER)
- E.** RAFFINATO 90 mm PILLAR UNIT
- F.** RAFFINATO 180 mm PILLAR UNIT
- G.** RAFFINATO UNIT CUT ON FIELD AS REQUIRED
- H.** CAST IN PLACE CONCRETE SLAB 4350 psi (30 MPa), 5" (125 mm) THICK
- I.** 4X4-4/4 (102X102-MW25.8XMW25.8) WELDED WIRE MESH AND/OR REBAR AS PER SITE CONDITIONS
- J.** 12" (300 mm) DIA. CONCRETE PILLAR, AS PER LOCAL CODE
- K.** 3/4" (20 mm) CLEAN STONE
6" (150 mm) THICK MIN. AS PER SITE CONDITIONS
- L.** GEOTEXTILE
- M.** NATURAL SOIL OR COMPACTED BACKFILL

QUANTITY OF MATERIALS REQUIRED

- York Counter top 24" x 36" x 2 1/4": **4**
- Raffinato 90 mm wall unit: **48 A**
- Raffinato 180 mm wall unit: **22 A**
- Raffinato 90 mm pillar unit: **16**
- Raffinato 180 mm pillar unit: **16**

NOTE: Appliances and utilities may vary for each project and are not shown on this drawing. This drawing is shown for inspiration only and surplus or shortage of materials may result. It is the user's responsibility to verify for the quantity of materials required. Secure the blocks using a heat resistant concrete adhesive. The installer must ensure that the installation and use of the grill island comply with local regulations and code requirements. Concrete pillars extending to frost line may be required as per local code. Check your local building code before installing.