







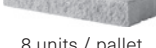

GRAPHIX

DESCRIPTION: Wall double-sided **TEXTURE:** Smooth & Split face

Specifications per pallet		Imperial	Metric
1	 8 units / pallet	Product dimension (L×D×H) 1 20 × 9 1/16 × 2 15/16	508 × 230 × 75
		Product dimension (L×D×H) 2 20 × 10 1/16 × 2 15/16	508 × 255 × 75
		Product dimension (L×D×H) 3 20 × 11 × 2 15/16	508 × 280 × 75
2	 8 units / pallet	Product dimension (L×D×H) 4 20 × 8 1/16 × 2 15/16	508 × 205 × 75
		Product dimension (L×D×H) 1A 20 × 9 1/16 × 2 15/16	508 × 230 × 75
		Product dimension (L×D×H) 2A 20 × 10 1/16 × 2 15/16	508 × 255 × 75
3	 8 units / pallet	Product dimension (L×D×H) 3A 20 × 11 × 2 15/16	508 × 280 × 75
		Product dimension (L×D×H) 4A 20 × 8 1/16 × 2 15/16	508 × 205 × 75
4	 8 units / pallet split on one side	Cubing	26.25 ft ² / 2.44 m ² 107.67 lin. ft / 32.51 m lin.
		Approx. Weight	2 773 lbs / 1 258 kg
		Number of rows	8
		Coverage per row	3.28 ft ² / 0.30 m ²
1A	 8 units / pallet Left corner unit	Lin. coverage per row	13.33 lin. ft / 4.06 lin. m
2A	 8 units / pallet Right corner unit		
3A	 8 units / pallet Left corner unit		
4A	 8 units / pallet Right corner unit, split on one side		

Pallet Overview

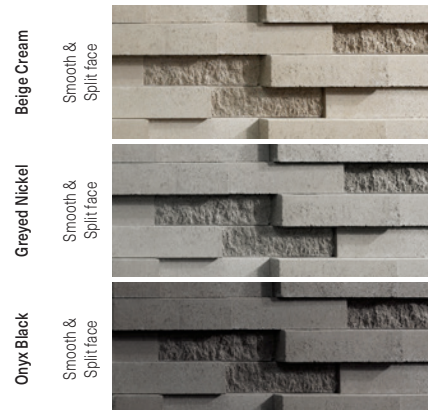
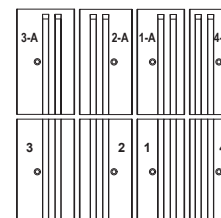

NOTES

See page 6 for icons description.

COMPATIBLE CAPS

See page 145 for product compatibility.

See page 146 to 161 for more technical information.

CLEAN SAND/GRAVEL/ SAND AND GRAVEL MIXES ($\phi=34^\circ$, $\gamma = 120$ pcf)
GEOGRID: MIRAGRID 2XT BY TENCATE (RFd=1.10, RFcr=1.45, RFid=1.25, Cds=0.9, Ci=0.9)

CASE N° 1 :
No Surcharge
No Backslope
No Toe Slope

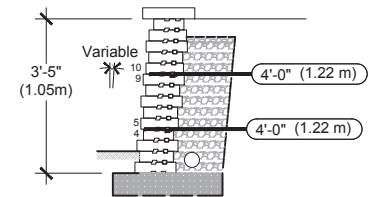
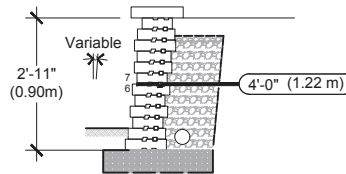
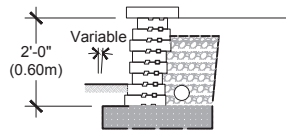

VISIT WWW.TECHO-BLOC.COM FOR COMPLETE DESIGN CHART DOCUMENT
(USA AND CANADA VERSIONS)

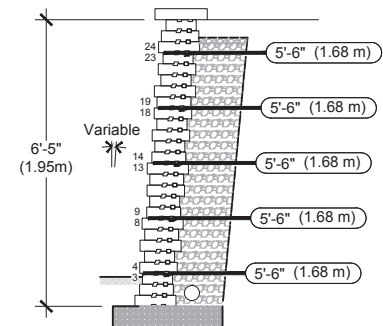
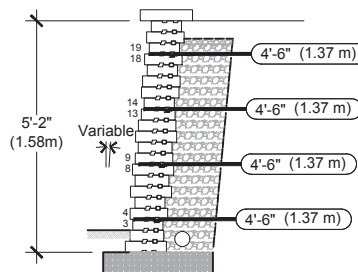
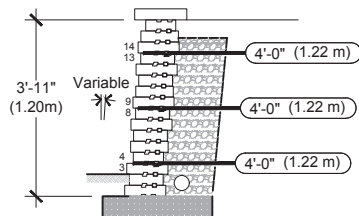

1. The information contained in the design charts is supplied for information purposes only and as such should only be used for preliminary designs.
2. The height (H) of the wall is the total height from the leveling pad to the top of the wall not including the thickness of the cap.
3. Soil parameters: reinforced soil ($\phi = 34^\circ$, $\gamma = 120$ pcf); retained soil ($\phi = 34^\circ$, $\gamma = 120$ pcf); foundation soil ($\phi = 34^\circ$, $\gamma = 120$ pcf)
4. A qualified engineer should be consulted for the final design to be used for construction.
5. The foundation soil must be able to support the wall system. The bearing capacity of the foundation soil, settlement, and global stability must be verified and validated by a qualified geotechnical engineer.
6. The seismic analysis is not included.
7. The design charts do not apply to tiered walls.
8. The charts assume that the walls are constructed in accordance with Techo-Bloc specifications, good construction practice and an adequate drainage system.
9. The geogrid layout has been optimized to satisfy the design requirements of the NCMA's Design Manual for Segmental Retaining Walls, 3rd Edition.
10. The minimum burial depth must be 6 in (150 mm) or 10% of the exposed height, whichever is greater.
11. Engineering judgement should be used when interpolating between heights.
12. Techo-Bloc and its predecessors, successors, beneficiaries, employees, associates, administrators and insurers accepts no liability for the incorrect use of information contained in the design charts.
13. For further information, please contact our technical service department.

INSTALLATION GUIDE

FREESTANDING WALLS - GRAPHIX

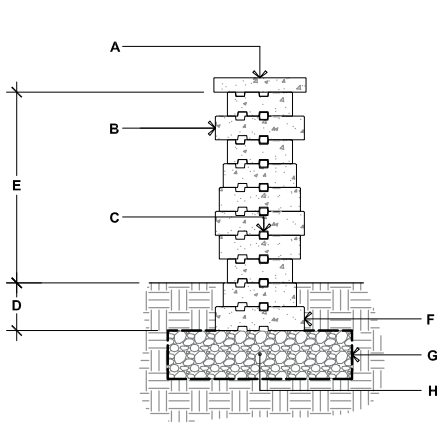

GRAPHIX

- A. TECO-BLOC CAP UNIT SECURED TO UNIT BELOW WITH CONCRETE ADHESIVE
- B. GRAPHIX DOUBLE-SIDED WALL UNITS SECURE EACH ROW WITH CONCRETE ADHESIVE
- C. CONNECTOR
- D. EMBEDMENT DEPTH, 6" (150 mm) MIN.
- E. 23 1/2" (600 mm) MAX.
- F. FOR THE FIRST ROW, ALWAYS USE THE DEEPER GRAPHIX BLOCK
- G. GEOTEXTILE
- H. COMPACTED GRANULAR LEVELING PAD, 6" (150 mm) THICK MIN. THICKNESS ACCORDING TO PROJECT SPECIFIC CONDITIONS

90° CORNER OF A DOUBLE-SIDED WALL

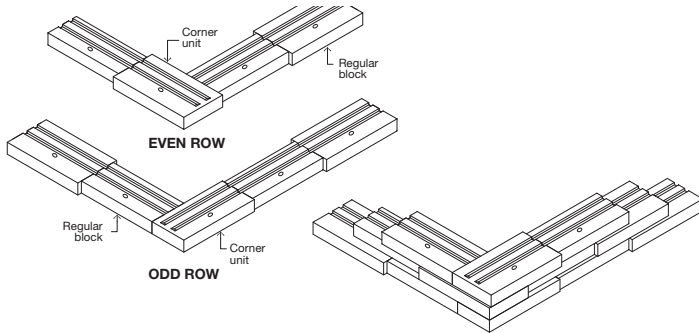

1. Alternate odd and even rows.
2. Stagger joints from one row to the next.
3. Glue all modules at each row with concrete adhesive.
4. Connectors are not illustrated to avoid overloading the image.
5. It is possible to alternate the blocks (1, 2, 3 or 4) in the same row to create different patterns. However, a corner block (1A, 2A, 3A or 4A) must always be present at the end of a row and must be alternated for each subsequent row.
6. At the corner, make sure to place the blocks so that the grooves of the block cannot be seen.

DOUBLE-SIDED WALL - END OF A STRAIGHT WALL

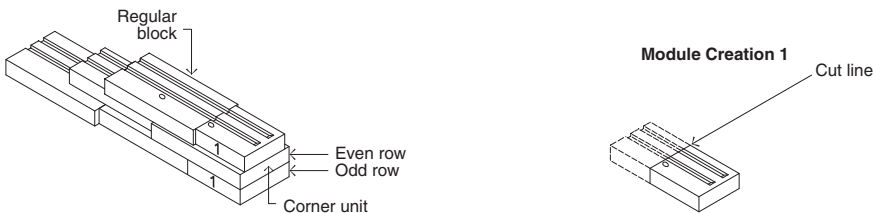

* It is possible to alternate the blocks (1, 2, 3 or 4) in the same row to create different patterns. However, a corner block and a cut corner block (1A, 2A, 3A or 4A) must always be present at the end of a row and must be alternated for each subsequent row.

INSTALLATION GUIDE

PILLARS - GRAPHIX

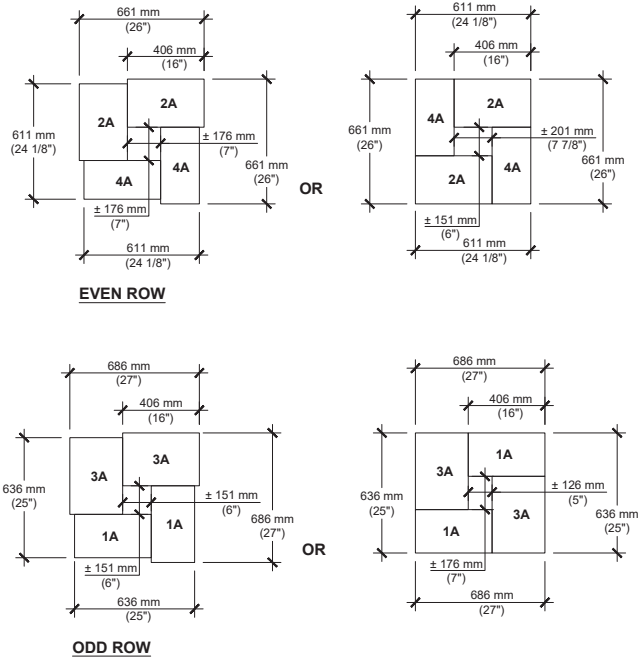
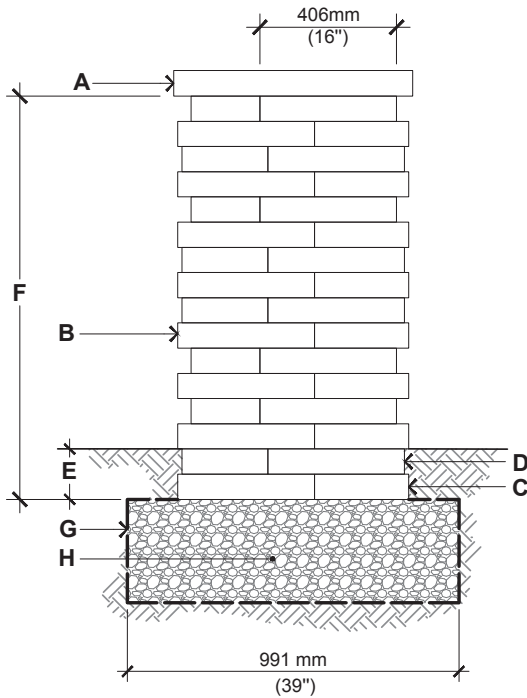

- NOTES:
- ALL UNITS MUST BE CUT ON FIELD
 - USE A CHISEL FOR DESIRED SPLITTED TEXTURE FACE

GRAPHIX

- A.** PILLAR CAP UNIT (SECURE WITH CONCRETE ADHESIVE)
- B.** GRAPHIX CORNER UNIT
SECURE EACH ROW WITH CONCRETE ADHESIVE
CUT EACH BLOCK AT 16" (406 mm) FROM THE CORNER EDGE
- C.** USE THE BLOCKS 1A-3A FOR THE ODD ROWS
- D.** USE THE BLOCKS 2A-4A FOR THE EVEN ROWS
- E.** EMBEDMENT DEPTH 6" (150 mm) MIN.
- F.** 23 5/8" (600 mm) HEIGHT PER PALLET
47 1/4" (1200 mm) MAXIMUM HEIGHT
- G.** GEOTEXTILE
- H.** COMPACTED GRANULAR BASE 6" (150 mm) THICK MIN.
THICKNESS ACCORDING TO PROJECT SPECIFIC CONDITIONS

For all possible combinations of pillars and caps, please refer to the correspondence table on page 145